



**weisstechnik**<sup>®</sup>  
a schunk company

mediclean<sup>®</sup>

Clean air systems in  
operating theatres

[www.weiss-technik.com](http://www.weiss-technik.com)

# Play it safe when it comes to clean air for operating theatres!

Do you want to optimally supply clean air to the operating theatre and reliably protect against particles and surgical smoke? This is where we can support you.



## Clean air systems for optimum safety.

OT clean-air canopies must meet the highest requirements in order to optimally protect patients and staff. At the same time, they must work economically. That is why we are offering you tailor-made clean air systems with unidirectional flow from a single source. They meet all relevant national and international norms and standards, such as DIN 1946 T4, HTM 03-01 and SNIP.

## Unidirectional flow.

Our OT clean-air canopies create a low-particle protective zone that reliably screens the wound area, the instrument table and the surgical staff from the environment. That reduces the bacterial burden in sensitive areas by up to 90%\*. At the same time, it protects the surgical staff from surgical smoke.

\*Results of the study "Reduction of Airborne Bacterial Burden in the OR by Installation of Unidirectional Displacement Airflow (UDF) Systems".

# Innovation and experience from a single source.

Clean air systems for operating theatres.

## Versatile and tailor-made.

Our range includes clean-air canopies in the form of recirculating air canopies (ULA) and filter surface canopies (FFA). If required, they can be expanded with innovative options, e.g. an air curtain system, a continuous particle monitoring system and an extraction for surgical smoke gases.



## Innovative and proven.

We are your experienced partner for innovative, reliable and efficient clean air technology for operating theatres. Our systems are deployed in more than 9,000 operating theatres around the world. Our reliable solutions incorporate the latest scientific findings and meet all relevant legal requirements.



## From a single source.

We comprehensively support you from the initial design to installation up until the solution is taken into service. We are the only company in the world that is a single source provider of OT clean-air canopies, air-conditioning units, air-conditioning systems and services that are so optimally coordinated with each other.

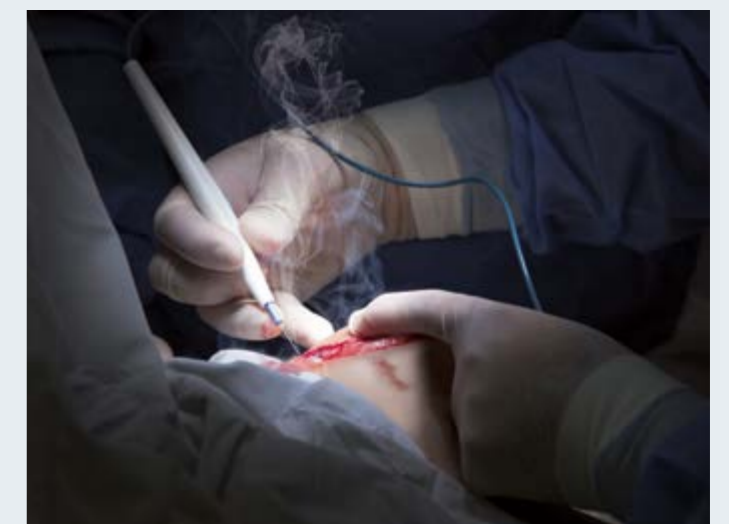



## Clean air system solutions for your operating theatre.

You can optimally and economically reach your hygiene goals using clean air systems from weissttechnik.

The quality of clean air in operating theatres is an important factor in the success of a surgical procedure. Furthermore, it is crucial to protect patients and surgical staff from surgical smoke. Our clean air systems are suitable for the most varied structural conditions, hygiene requirements and surgical fields. For that reason, great attention is paid to the prevention of infection and work place safety.

### ULA OT circulating air canopy

Recirculating air canopies are fully integrated in the suspended canopy and are also suitable for the redevelopment of existing installations.

### OFFA OT filter surface canopy

Filter surface canopies are often the best solution if the air-conditioning units are situated in a neighbouring room.

ULA system

FFA system

UWM system

Options

### UWM wall-mounted recirculating-air module

Wall-mounted recirculating-air modules are especially suitable for use in operating theatres without enough space for canopy-mounted recirculating-air modules.

### Wide range of options

The versatile options expand the range with respect to the prevention of infection, work place safety, hygiene and comfort.

# ULA OT recirculating air canopy

Reliably protect patients and staff by integrating the complete system in the suspended canopy.



### How it works

The optimised low-turbulence recirculating air canopy consists of an air outlet element, terminal airborne particle filters, a plenum with sound absorbers and recirculating-air modules. In order to guarantee maximum safety alongside optimum efficiency, the ULA mixes the return air and supply air in the recirculating-air module. For this purpose, the theatre air is sucked into the recirculating-air module and mixed with the supply air coming from the air-conditioning unit. The mixed air is transported to the plenum positioned above the filter. From there, it is conducted in its particle filtered state as clean air into the operating theatre and the preparation area, where it forms a protective zone.

### Protective Zone

The protective zone is formed by way of unidirectional flow. It covers the total sterile environment for the surgical procedure. The sterile environment also includes the material and instrument table as well as the persons in sterile clothing. As a result, the patient, surgical staff, material and instruments are optimally protected against particles and airborne bacteria. The area of the protective zone is marked on the floor.

### Diagram of a ULA system

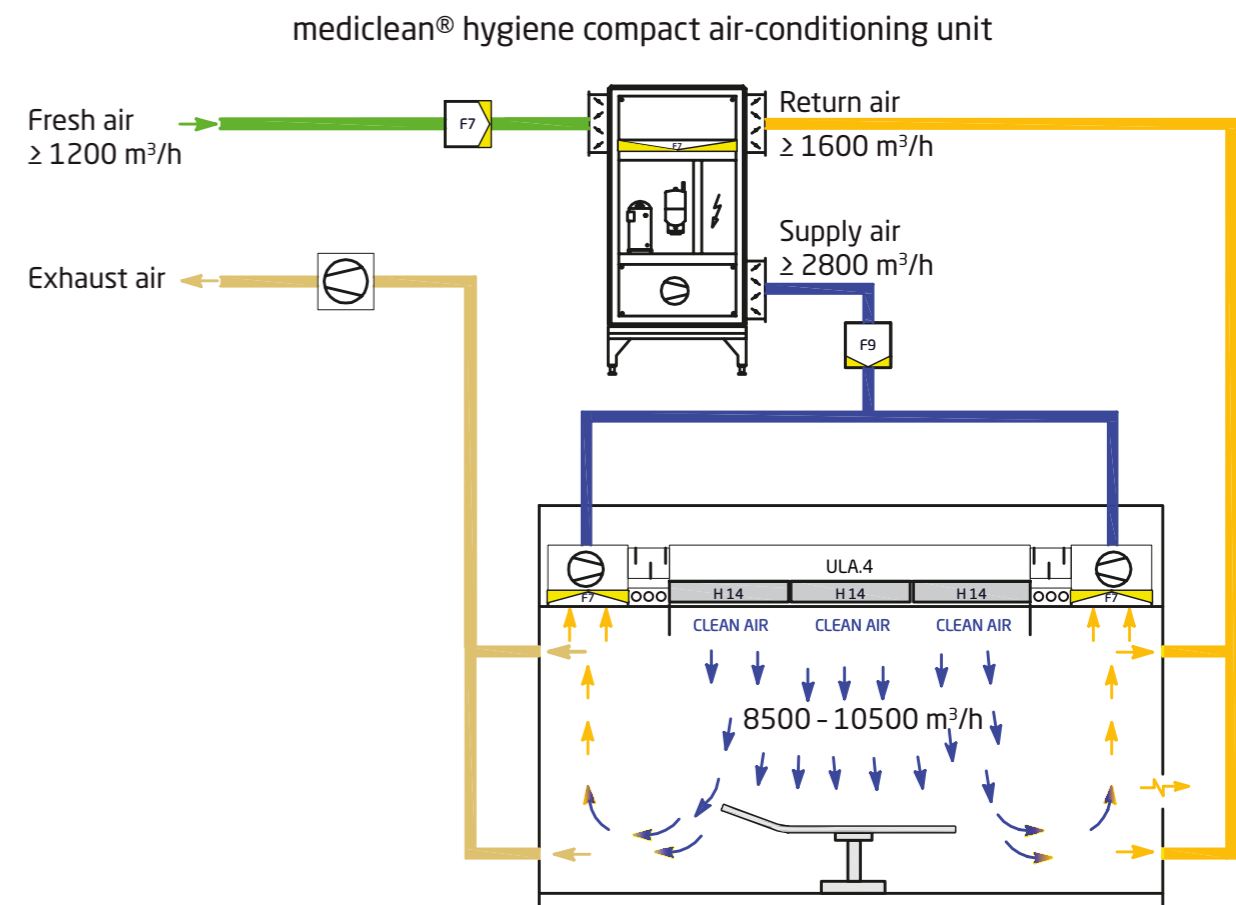

### Your benefits:

- Optimum energy consumption
- Reduction of the duct size coming from the air-conditioning unit
- Air flow rate adjustment possible independent of air-conditioning unit and duct system
- Mixing of return air and supply air in the recirculating-air module, i.e. outside of the canopy body and as a result there is no temperature difference
- For the redevelopment of existing installations

# ULA OT recirculating air canopy

Thanks to the variable aluminium frame system you can optimally adapt the OT canopy to your structural conditions.

## Dimensions and design

The size of the protective zone is determined by the surgeons and hygienists, and depends on functional requirements and supply requirements of the operating theatre. In our experience, a protective zone of at least 3 x 3 metres is recommended.

## Specifications

- Air outlet element: Polyester cloth (Differential flow or uniflow)
- Airborne particle filter: H14 (in accordance with DIN EN 1822)
- Plenum: Anodised aluminium or stainless steel
- Recirculating-air module: Anodised aluminium (Intake module including stainless steel microfabric and F7 filter (in accordance with DIN EN ISO 16890))

Type	Length A	Length B	Clean air volume DIN 1946 T4 <sup>1</sup>	Fresh air content	Weight <sup>3</sup>	Clean air volume HTM 03-01 <sup>2</sup>	Fresh air content	Weight <sup>4</sup>
	mm	mm	m³/h	m³/h	kg	m³/h	m³/h	kg
26/26	2575	2575	5800	3800	700	9000	5200	740
29/26	2879	2575	6500	4300	720	10200	6100	760
29/29	2879	2879	7200	4700	770	11400	6400	810
32/26	3185	2575	7100	4600	770	11200	6200	810
32/29	3185	2879	8000	5200	790	12600	7400	830
32/32	3185	3185	8800	5700	830	13900	7900	870
35/26	3489	2575	7800	5000	810	12300	6900	850
35/29	3489	2879	8800	5700	840	13800	7800	880
35/32	3489	3185	9700	6300	850	15200	9000	890
35/35	3489	3559	10800	6400	900	17000	9000	940

<sup>1</sup> At 0.24 m/s outflow speed.  
<sup>2</sup> At 0.38 m/s outflow speed.  
<sup>3</sup> With plenum height of 550 mm, recirculating-air module height 550 mm.  
<sup>4</sup> With plenum height of 550 mm, recirculating-air module height 690 mm.

Other sizes available on request.

Sizes 32/32, 35/32 and 35/35 4 parts, all other sizes 2 parts.

We reserve the right to make technical changes without prior notice.

### Type code (example)

ULA.4 32/32/5/6

- 6 = Height of recirculating-air module (690 mm)
- 5 = Height of plenum (550 mm)
- 32 = Length of the clean-air canopy field on the side of the recirculating-air module (3185 mm)
- 32 = Width of the clean-air canopy field (3185 mm)
- 4 = Version number
- ULA = Type designation for OT circulating air canopy

Diagram of a ULA OT recirculating air canopy

Splitting the recirculating-air module is possible

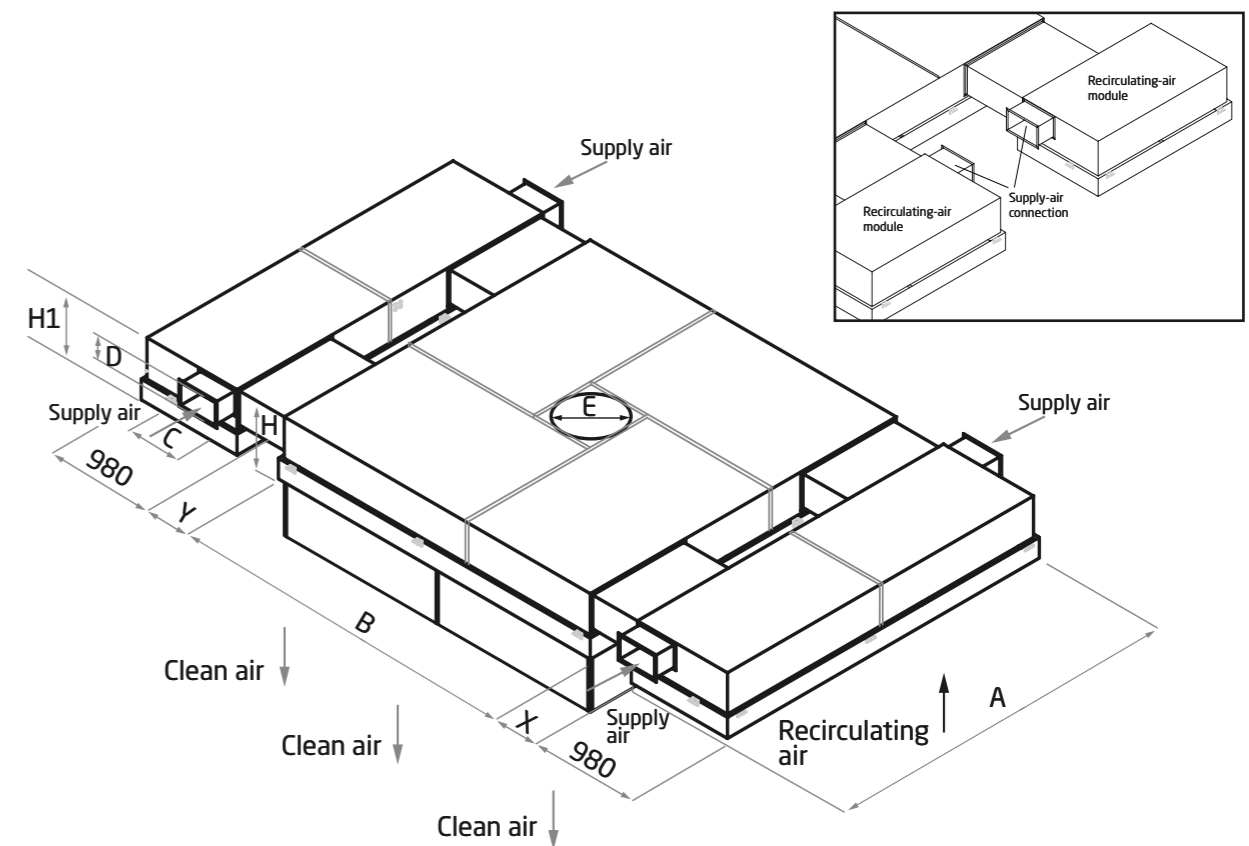

### All sizes:

Plenum Height (H)	Recirculating-air module Height (H1)	Connection sleeve	Connection sleeve Width (C)	Connection sleeve Height (D)	Feedthrough for lamps (E)
mm	mm	Number	mm	mm	mm
480	480	4	350	200	578
550	550	4	350	200 (250 <sup>1</sup> )	578
550	690	4	350 (390 <sup>1</sup> )	270 (320 <sup>1</sup> )	578

X/Y = 350 mm with 2 rows/460 mm with 3 rows LED light  
 X/Y = 300 mm with 2 lamps/416 mm with 3 lamps T5 light

<sup>1</sup> With ULA.4 35/35.

We reserve the right to make technical changes without prior notice.

# FFA OT filter surface canopy

The intelligent clean air solution when the air-conditioning unit is located in the adjoining room.



## How it works

The OT filter surface canopy is supplied with 100% air from the air-conditioning unit. This air is transported via the duct system to the plenum positioned above the filter. From there, it is conducted in its particle filtered state as clean air into the operating theatre and the preparation room, where it forms a protective zone.

## Protective Zone

The protective zone is created by way of a unidirectional flow. It covers the total sterile environment for the surgical procedure. The sterile environment also includes the material and instrument table as well as the persons in sterile clothing. As a result, the patient, surgical staff, material and instruments are optimally protected against airborne particles and bacteria. The area of the protective zone is marked on the floor.

Diagram of an FFA system with several operating theatres

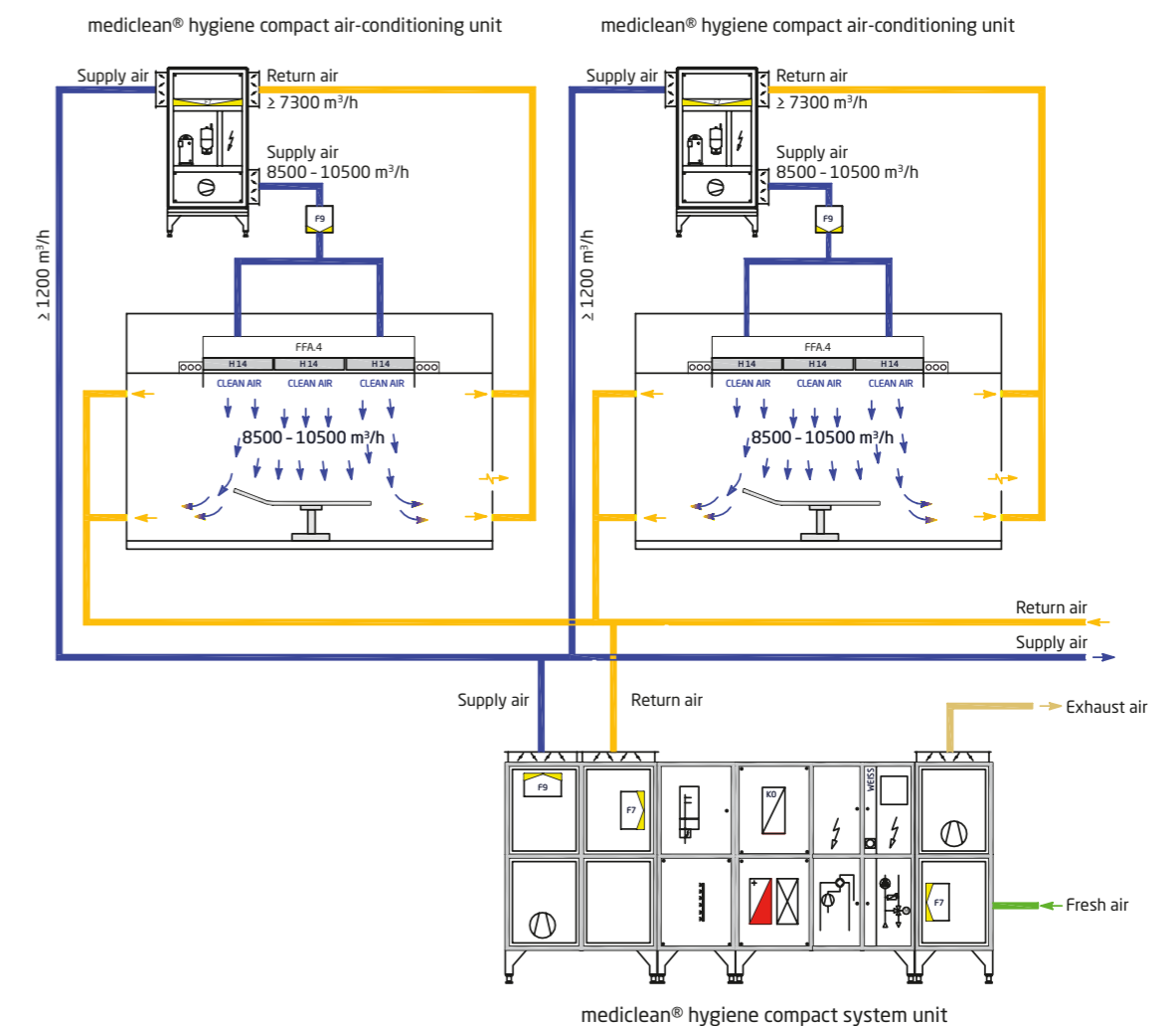

## Your benefits:

- Mixture of supply air and recirculating air directly in the air-conditioning unit
- Easily accessible gauging heads for inflow and measurement of the test aerosol
- Suitable for low suspended canopy heights

# FFA OT filter surface canopy

Great versatility means that individual adaptations to structural conditions are always possible.

Type	Length A	Width B	Clean air volume DIN 1946 T4 <sup>1</sup>	Connection sleeve width C <sup>2</sup> (450 mm <sup>4</sup> )	Connection sleeve width C <sup>3</sup> (300 mm <sup>5</sup> )	Clean air volume HTM 03-01 <sup>2</sup>	Connection sleeve width C <sup>3</sup> (450 mm <sup>4</sup> )	Connection sleeve width C <sup>3</sup> (550 mm <sup>6</sup> )
	mm	mm	m <sup>3</sup> /h	mm	mm	m <sup>3</sup> /h	mm	mm
14/14	1355	1355	1600	800	2x800	2500	2x700	2x500
14/18	1355	1659	2000	1000	2x1000	3100	2x800	2x600
14/20	1355	1965	2300	1100	2x1100	3600	2x1000	2x700
14/24	1355	2269	2700	1300	2x1300	4200	2x1100	2x800
14/26	1355	2575	3100	1500	2x1500	4800	2x1200	2x900
18/18	1659	1659	2400	1200	2x1200	3800	2x1000	2x700
18/20	1659	1965	2900	1400	2x1400	4400	2x1200	2x800
18/24	1659	2269	3300	1600	2x1600	5100	2x1300	2x900
18/26	1659	2575	3700	1800	2x1800	5800	2x1500	2x1100
18/29	1659	2879	4200	2000	2x2000	6500	2x1600	2x1100
20/20	1965	1965	3400	1600	2x1600	5300	2x1300	2x900
20/24	1965	2269	3900	1900	2x1900	6100	2x1500	2x1000
20/26	1965	2575	4400	2100	2x2100	6900	2x1700	2x1100
20/29	1965	2879	4900	2400	2x2400	7700	2x1900	2x1300
20/32	1965	3185	5500	2700	2x2700	8500	2x2100	2x1400
24/24	2269	2269	4500	2100	2x2100	7000	2x1700	2x1200
24/26	2269	2575	5100	2400	2x2400	8000	2x2000	2x1400
24/29	2269	2879	5700	2700	2x2700	8900	2x2200	2x1500
24/32	2269	3185	6300	2900	2x2900	9900	2x2400	2x1700
24/35	2269	3489	6900	2x1600	3x2100	10800	3x1800	3x1200
26/26	2575	2575	5800	2x1400	3x1900	9000	3x1600	3x1000
26/29	2575	2879	6500	2x1600	3x2100	10200	3x1700	3x1100
26/32	2575	3185	7100	2x1800	3x2300	11200	3x1900	3x1200
26/35	2575	3489	7800	2x1900	3x2400	12300	3x2000	3x1300
29/29	2879	2879	7200	2x1800	3x2300	11400	3x1900	3x1200
29/32	2879	3185	8000	2x1900	3x2600	12600	3x2100	3x1400
29/35	2879	3489	8700	2x2100	4x2100	13800	4x1700	4x1100
32/32	3185	3185	8800	2x2100	4x2200	13900	4x1700	4x1100
32/35	3185	3489	9700	2x2400	4x2400	15200	4x1900	4x1300
35/35	3489	3559	10800	2x2700	4x2700	17000	4x2100	4x1500

<sup>1</sup> At 0.24 m/s outflow speed.

<sup>2</sup> At 0.38 m/s outflow speed.

<sup>3</sup> Without louver damper, with louver damper, connection sleeve width available on request.

<sup>4</sup> At plenum height of 450 mm.

<sup>5</sup> At plenum height of 300 mm.

<sup>6</sup> At plenum height of 550 mm.

From size 20/20 2 parts, from size 32/32 4 parts.

Other sizes available on request.

**We reserve the right to make technical changes without prior notice.**

Diagram of an FFA OT filter surface canopy

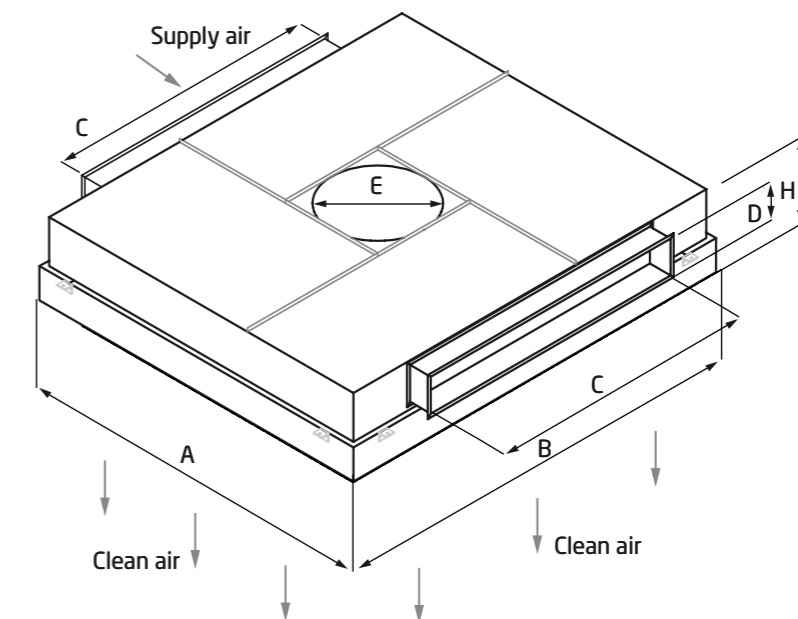

### Dimensions and design

The size of the protective zone is determined by the surgeons and hygienists, and depends on functional requirements and supply requirements of the operating theatre. In our experience, a protective zone of at least 3 x 3 metres is recommended.

### Specifications

- Air outlet element: Polyester cloth (Differential flow or uniflow)
- Airborne particle filter: H14 (in accordance with DIN EN 1822)
- Plenum: Anodised aluminium or stainless steel

### All sizes:

Plenum Height (H)	Connection sleeve Height (D)	Feedthrough for lamps (E)
mm	mm	mm
300	80	578
450	200	578
550	300	578

### Type code (example) FFA.4 26/26/4

- 4 = Height of plenum (450 mm)
- 26 = Length of the clean air canopy field (2575 mm)
- 26 = Width of the clean air canopy field (2575 mm)
- 4 = Version number
- FFA = Type designation for filter surface canopy

**We reserve the right to make technical changes without prior notice.**

## FFA system with UWM wall-mounted recirculating-air module

The ideal alternative when there is not enough space in the suspended canopy.



### How it works

The wall-mounted recirculating-air module can either be installed in front of the wall, as an integrated component of a lightweight construction wall, or in an adjoining room. The recirculating air is sucked out of the operating theatre through the fluff separator directly on the wall-mounted

recirculating-air module. Then it is filtered and conducted through the sound absorber with optional cooling. After that, the recirculating air from the fan is conducted with the supply air from the air-conditioning unit into the plenum of filter surface canopy that is positioned above the filter.

Diagram of a FFA system in combination with a UWM system

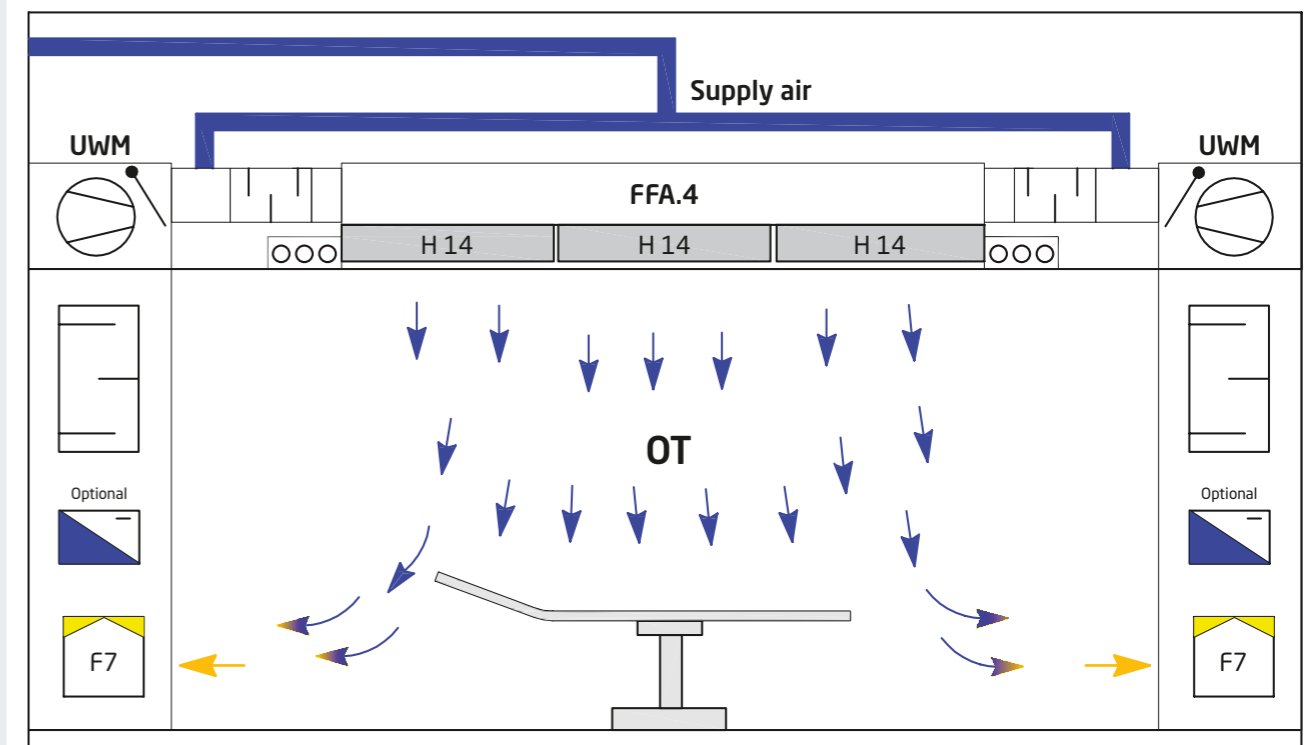

### Your benefits:

- Reduced sound pressure level when installed in adjoining room
- Service and maintenance can be performed outside the operating theatre
- Easily accessible fluff separator designed for machine cleaning
- Use of a dry cooler is possible as an option



# UWM wall-mounted recirculating-air module

You can choose whether to use it in combination with FFA OT filter surface canopy or on its own.



## Specifications

Housing:	Stainless steel with glass fibre fabric inside
Fan module:	Two fans with a motor (double shaft) including backflow prevention dampers
Sound absorber/cooling module:	Height is variable according to the clear room height
Dry cooler:	Optional: tube/lamella/frame: Cu/Al stainless steel
Recirculating air-intake/filter module:	Stainless steel microfibre suitable for washing machines (fluff separator), filter in F7 filter class in accordance with DIN EN ISO 16890

## External dimensions

Full module	Recirculating air-intake/filter module	Sound absorber/cooling module	Fan module	Blind on the base	Weight of full module
WxHxD mm	WxHxD mm	WxH <sup>1</sup> xD mm	WxHxD mm	WxHxD mm	kg
1100x3450x450	1100x1300x450	1100x1580x450	1100x500x450	1100x70x450	approx. 280

<sup>1</sup> Height of sound absorber module variable (in accordance with the clear room height).

Customised solutions available on request.

We reserve the right to make technical changes without prior notice.

## Fan

Recirculating air volume flow <sup>1</sup>	Current consumption	Input power	Power supply connection
m <sup>3</sup> /h	A	kW	VAC/Hz
1100-3000	4.1-5.2	0.7-0.91	230/50

<sup>1</sup>Higher recirculating air volume flows available on request.

We reserve the right to make technical changes without prior notice.

## Dry cooler

Recirculating air volume flow <sup>1</sup>	Cooling output, sensitive	Medium	Temperature medium supply/return	Weight
m <sup>3</sup> /h	kW		°C	kg
3000	3.3	Water	14/16	approx. 15
Temperature air inlet	Relative humidity air inlet	Temperature air outlet	Relative humidity air outlet	
°C	%	°C	%	
23	57	19.8	70	
Chilled water volume	Pressure loss air	Pressure loss medium	Chilled water connections	
m <sup>3</sup> /h	Pa	kPa	Inch	
1.4	50.3	8.4	1	

<sup>1</sup>Higher recirculating air volume flows available on request.

We reserve the right to make technical changes without prior notice.

# CPM continuous particle monitoring

Count on the world's first real-time monitoring system for airborne particles and bacterial burden in the operating theatre.



Experience our CPM system live in our showroom!  
<https://www.youtube.com/watch?v=9T5NkfdzIMA>



## Application area

The CPM system meets the increasing hygiene requirements in the operating theatre and helps to effectively protect patients from airborne particles and bacterial burden. Controlling the air quality can provide an important aid in avoiding nosocomial infections through contaminated surgical instruments. In this way, it serves to ensure quality. Furthermore, it allows the exact documentation of the clean air quality.

## How it works

The air is sucked in through a vacuum pump via a tube right in the critical area above the surgical instruments or the instrument table, and the air is conducted through a particle counter that continually measures the air quality. If the air pollution increases, e.g. through the vigorous movement of the surgical staff, then the clean air supply is also automatically increased for the period of the increased burden. A screen or a light shows the current status of the air quality at all times.

Diagram of a continuous particle monitoring system: CPM system in combination with a ULA system

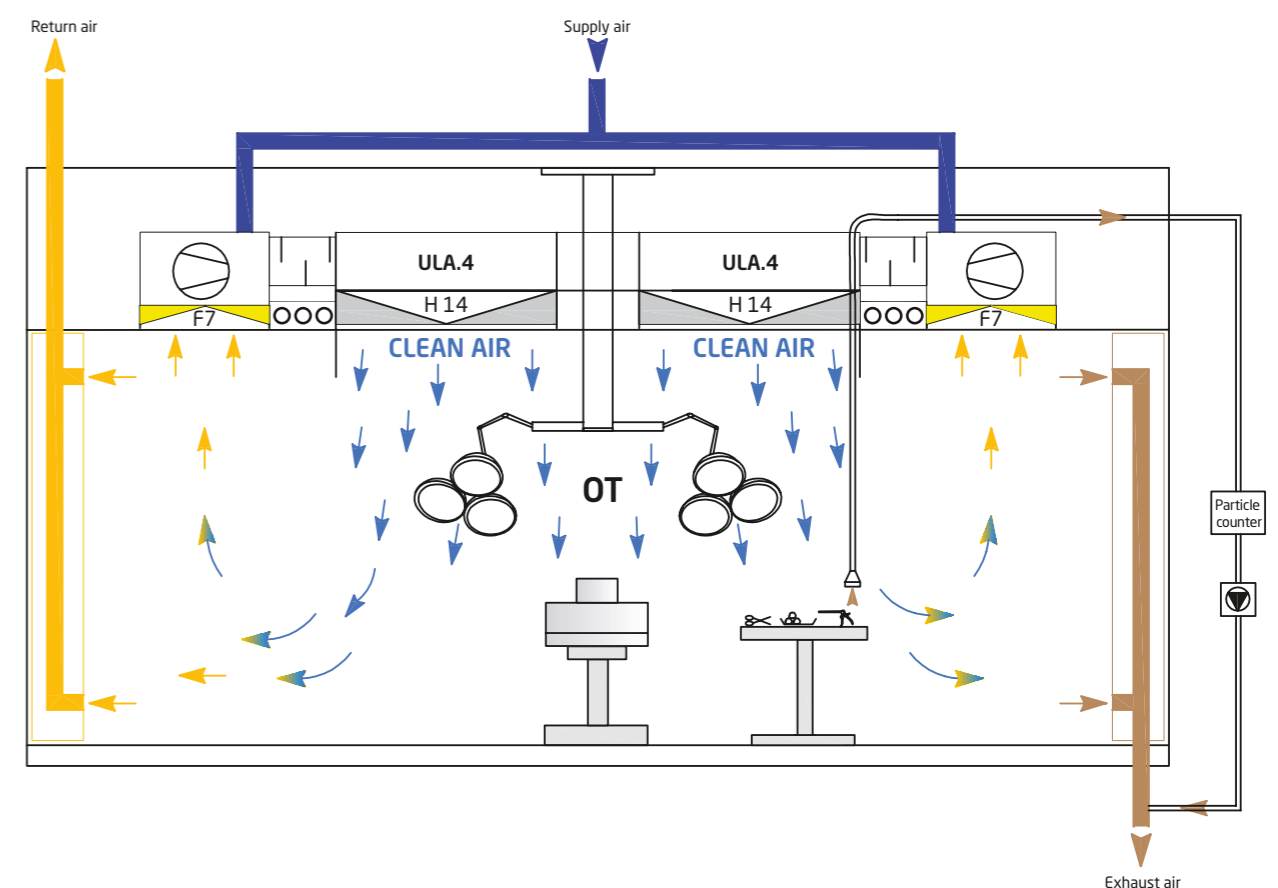

## Your benefits:

- Prevention of infection through the continual monitoring of the air quality
- Light-screen display to show the current air quality
- Increasing awareness among the surgical staff and protection of the sterile chain
- Clean air supply adapted to suit requirements
- Quality management possible for every operation thanks to documentation

## SSV surgical smoke extraction

With the SSV surgical smoke extraction you can reliably protect the surgical team against dangerous smoke and always ensure a clear view.



### Application area

Increasingly often high frequency, radio frequency, laser and ultrasound instruments, which lead to the formation of surgical smoke, are used in modern surgery. The harmful smoke gases and aerosols rise upward and the surgical staff inhales them. Surgical masks and mobile extraction devices have proven to be less practical in this regard. The surgical smoke extraction sucks smoke from where it is formed: right on the wound. In doing so, the extraction tube can be positioned by the surgeon so that an optimum extraction effect with a clear view can be achieved.

### How it works

The extracted air is conducted upwards via a tube and is transported through a vacuum pump or a fan directly to the exhaust air. The process significantly reduces smoke particles and unpleasant odors. Furthermore, regular filter changes are not necessary unlike with mobile devices. The placement of the pump or fan outside of the operating theatre avoids noise pollution. In combination with a unidirectional flow canopy, the innovative smoke extraction offers the best efficiency and therefore optimum protection in addition to comfortable working conditions for the surgical staff. Alternatively, the extraction can be coupled to the surgical instrument and can be automatically switched on and off.

Diagram of an SSV system in combination with an FFA system

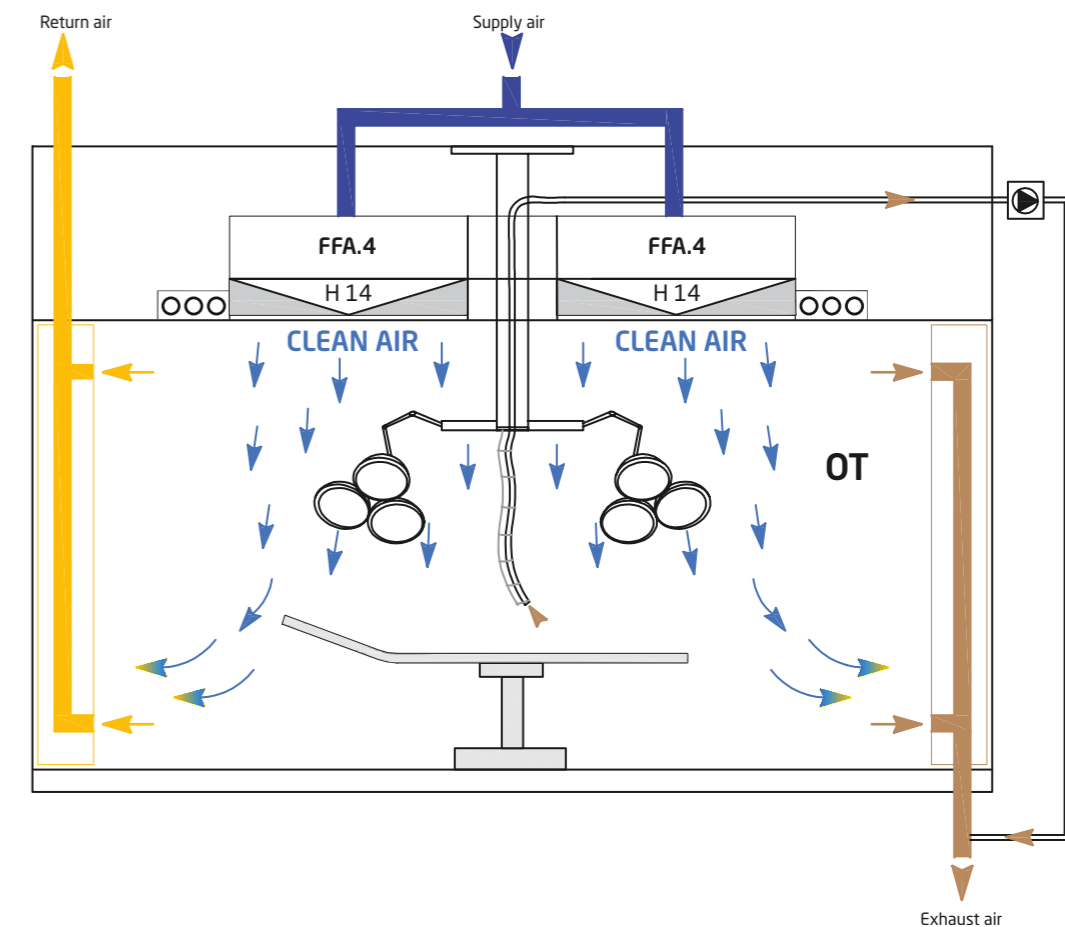

### Your benefits:

- Optimum protection of workers against surgical smoke, aerosols, nanoparticles and other hazardous substances
- Clear view thanks to direct extraction and possibility to work independently without additional staff
- Low noise level thanks to the connection to the exhaust air (no recirculating air)
- No noise generation since the pump is outside the operating theatre
- Easy to maintain, no filter change necessary

## GSS glass flow stabiliser

Enlarge the protective zone in the operating theatre.



### How it works

The permanently installed flow stabiliser is made of high quality compound safety glass. It enlarges the protective zone by preventing the constriction of the laminar air flow under the outlet. As a result, the penetration of airborne particles and bacterial burden from outside into the protective zone is prevented in the area of the glass pane.

The longer the glass pane is, the bigger the protective zone is. When planning, it must be ensured that no collision risk with medical installations, e.g. canopy-mounted supply units, arises.

## ACS air curtain system

The innovative alternative to increase the size of a protective zone.

### Application area

The air curtain system is an innovative flow stabiliser - complete and screenless. It is ideally suited for operating theatres, in which there is an increased risk of collision when using a stationary glass flow stabiliser due to a multitude of medical installations (e.g. operation lamps, mobile angiographic units or canopy-mounted supply units).



### How it works

In the air curtain systems, the air flow is stabilised by air instead of a glass pane. The air is guided via the frame profile and duct tracks that are integrated around in the frame profile. The air volume can be regulated very easily.



# OPAS operating theatre air extraction system

For pumping extract air out of the operating theatre.



### Application area

The OPAS operating theatre air extraction system is available as a wall or corner design. Symmetrical extraction in all four corners of the room is recommended. The extraction chamber is either visibly positioned in front of the wall/in the corner or is integrated into a lightweight construction wall. An inspection door with sash fastener allows for easy access and simple cleaning. The FA fluff separators, optionally with volume setting, are located in the extract air openings that are positioned near the floor and canopy.

Type	Front side (mm)	Leg length (mm)	Max. extract air volume (m³/h)
<b>CORNER DESIGN</b>			
With integrated fluff separator top/bottom without volume setting			
OPAS-E 500	approx. 700	500	1500
OPAS-E 700	approx. 1000	700	3000
With integrated fluff separator top/bottom with volume setting			
OPAS-E-ME 500	approx. 700	500	1000
OPAS-E-ME 700	approx. 1000	700	2500
<b>WALL DESIGN</b>			
With integrated fluff separator top/bottom with volume setting			
OPAS-W 500/250	500	250	1500
OPAS-W 700/350	700	350	3000
With integrated fluff separator top/bottom with volume setting			
OPAS-W-ME 500/250	500	250	1000
OPAS-W-ME 700/350	700	350	2500

Other sizes available on request.

We reserve the right to make technical changes without prior notice.

# FA fluff separator

Simply makes the duct system fluff free.

### How it works

The fluff separator is available with or without a volume setting and is designed to be installed in the extract air openings in the operating theatre. It ensures that the duct system and the downstream system components remain free from fluff. The fluff separators are made of a close meshed stainless steel wire mesh that is affixed in a stable, self-supporting and corrosion resistant stainless steel frame. The extract air is regulated by an air volume setting using counter rotating lamella or hit and miss dampers. The fluff separator can be easily removed without tools and is suitable for machine cleaning.

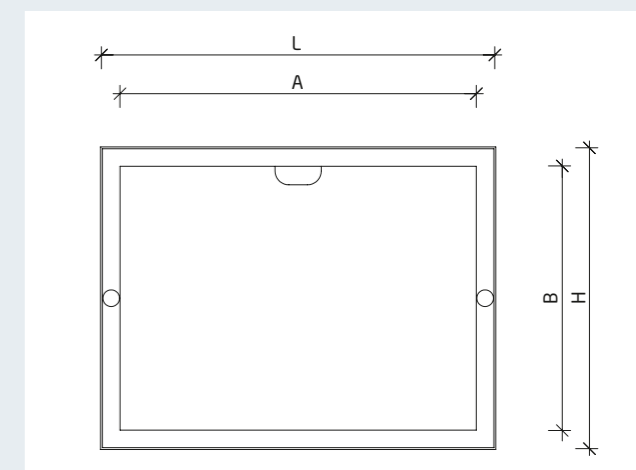

Dimensions				Basic design	With counter rotating volume setting		With hit and miss damper	
Grid size		Clear dimensions		Exhaust air volume flow	Exhaust air volume flow	Duct installation depth min.	Exhaust air volume flow	Duct installation depth min.
L mm	H mm	A mm	B mm	m³/h	m³/h	mm	m³/h	mm
355	250	310	210	470	350	200	315	200
455	250	410	210	640	470	200	410	200
555	250	510	210	810	590	200	520	200
455	350	410	310	990	700	250	610	250
555	350	510	310	1240	870	250	760	250
655	350	610	310	1500	1040	250	910	250

Other sizes available on request.

We reserve the right to make technical changes without prior notice.

## LED theatre lighting

To optimally light the operation area.



### Specifications

The LED theatre lighting is positioned circumferentially and directly on theatre room canopy (FFA/ULA) and is integrated in the aluminium frame system. The anti-glare LEDs have 4,000 K colour temperature, are neutral white, with

RA > 90, and meet protection class 1, as well as the IP65 type of protection. The specular louvers can be swivelled by +/- 30°. The lighting cover is made of compound safety glass and is resistant to disinfectant and UV radiation.

Lamps	Short design	Long design
	External dimensions WxDxH	
	mm	mm
2 rows	1250x460x90	1550x460x90
3 rows	1250x350x90	1550x350x90

We reserve the right to make technical changes without prior notice.

## IF infrared heating panel

The innovative alternative to conventional wall heating.



### How it works

If heat loads are lacking, the infrared heat panels ensure that a temperature difference of  $\geq 0.5$  K between supply air and extract-air temperature is generated. The innovative canopy heating generates a pleasant radiant heat with a short reaction time, which emits heat directly to solid

bodies. In doing so, the air is not heated, thus preventing dust turbulence. The infrared heat panels are easy to install or upgrade, and have smooth surfaces that are easy to clean and disinfect.

IF infrared heating panel		IF high power infrared heating panel		
Type	Heat output	Type	Heat output	External dimensions WxDxH without installation frame
	W		W	
IF 60/60	550	IFHP 60/60	650	593x593x36
IF 120/60	1100	IFHP 120/60	1300	1193x593x36
IF 120/30	550			1193x293x36

We reserve the right to make technical changes without prior notice.

## Top off your clean air system with additional options.

Our versatile range leaves nothing to be desired - everything from a single source.



### MVB media supply bridge

Customer specific connections for high and low voltage current, medical gases, communication, and data technology are integrated in the medical supply system. When the media supply bridge is used, an air guide skirt is automatically in place this prevents the penetration of airborne particles and bacteria from the outside into the protective zone in the area of the glass skirt. As well as the rectangular standard design, U, L and I shaped designs are also available. Upgrades are possible at any time.



### Fabric outlet in designer look

The attractively printed cover fabric pleasantly enhances the most sterile operating theatre atmosphere. Above all, for operations using spinal anaesthesia or local anaesthetic, it also helps calm the patient. The design can be selected according to the customer's wishes.

### MediClean hygiene compact air-conditioning unit

The MediClean hygiene compact air-conditioning units are particularly space-saving and are ideally suited to being integrated in existing buildings. In doing so, depending on requirements they can be placed as a single module or several module compact unit in central air-conditioning system or in an adjoining room. All control technology is already integrated in the system and an additional control cabinet is generally not needed.



### intelli.4® control system

The proven intelli.4® control system is deployed in all weisstechnik air-conditioning units. The controller with an open structure has a modular design and is suitable for all current and future controller generations. intelli.4® can be flexibly networked and has a wide range of different interfaces, including an interface to the building control technology. It can easily be expanded at any time in almost any way.



We measure ourselves by our service!

Want to know more?



**Learn more about our OT clean-air systems.**

**Case studies**

We are happy to present selected case studies on this subject to you.

**Technical articles**

We inform you competently and in a well-founded manner in our technical articles.

**Presentations**

Attend our presentations at a wide selection of events.

**Our services - lots of good arguments:**

**24/7-Service-Helpline:  
+49 6408 84-74**

- Global service network
- Wide range of preventive maintenance services
- Secure spare parts supply
- Special service operations available at all times
- Proper disposal of your old units with verification

A **weisstechnik** specialist is always close by.



# Passionately innovative.

**We work in partnership to support companies in research, development, production and quality assurance, with 22 companies in 15 countries at 40 locations.**

weisstechnik

**Test it. Heat it. Cool it.**



## Environmental simulation

The first choice for engineers and researchers for innovative, safe environmental simulation facilities. In fast motion, our test systems can simulate all the influences in the world and even in space. In temperature, climate, corrosive, dust or combined stress testing with its very high degree of reproducibility and precision.



## Heating technology

Experienced engineers and designers develop, plan and produce high-quality, reliable heating technology systems for a broad range of uses from heating and drying cabinets and microwave systems through to industrial furnaces.



## Air-conditioning technology, air dehumidification, cleanrooms

As the leading provider of cleanrooms, air-conditioning technology and air dehumidification, we consistently ensure optimal ambient conditions for people and machines. For industrial production processes, in hospitals, mobile operating tents or in the field of information and telecommunications technology. From project planning to implementation.



## Clean air and containment systems

With decades of experience and know-how, we guarantee the most sophisticated clean air and containment solutions. Our comprehensive and innovative range of products includes barrier systems, laminar flow systems, safety workbenches, isolators and airlock gate systems.

**Weiss Klimatechnik GmbH**

Greizer Straße 41-49

35447 Reiskirchen/Germany

T +49 6408 84-6500

info@weiss-technik.com

www.weiss-technik.com



Management System  
ISO 9001:2008

www.tuv.com  
ID 9108624460



**MIX**  
Papier aus verantwortungsvollen Quellen  
**FSC® C001704**

KT-MC-OP-01.1D/PP 1.0/08 2017

